



*Lamborghini*  
CALORECLIMA



**Clover**

Large water volume heat generator

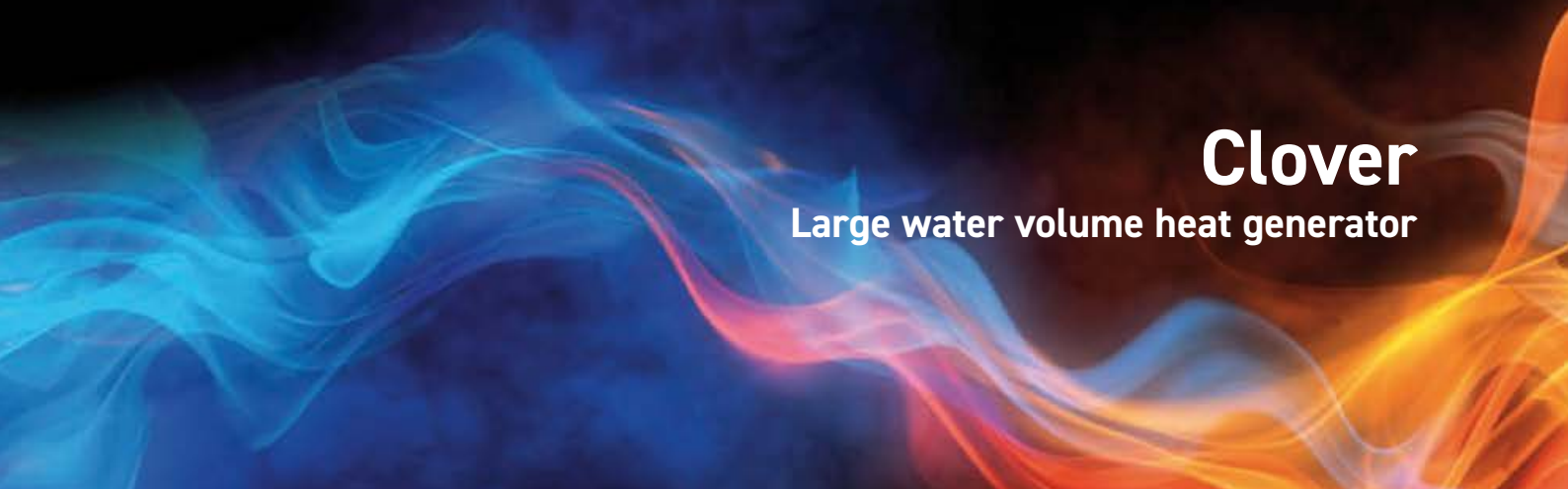



# THE IDEAL SOLUTION FOR EVERY SYSTEM

## THE DESIGN

The large water content of the boiler and the vertical configuration of the CLOVER series exchange group ensure extremely low load losses, also with high flow rates, enabling the generator to work with very high  $\Delta T$ .

All this translates into superior plant engineering flexibility that frees the designer from the limits imposed by the type of generator. It can also be connected directly to the system without the interposition of separation elements, even in the case of multiple-zone systems, usually characterised by significant variations of the flow rates and of the  $\Delta t$  between boiler delivery and return.

This features make it particularly suitable in the cases of:

### A) Systems with high water flow rates and modulating circulation systems

The generator, given its physical characteristics, is perfectly suited to working on systems with high water flow rates with multiple simultaneously operating "zones". The possibility of working in a very wide  $\Delta t$  range promotes combining with variable speed circulation and low consumption systems.

### B) Redevelopment of existing systems

Choosing a generator that can be integrated with every type of heat distribution system obviously leaves a broader scope for design. In addition, it can be perfectly paired with separation elements that can be typically positioned between the boiler and the system to prevent sludge ending up in the boiler, compromising its efficient operation.

### C) Replacing the old generator in thermal plants

Its "independence" from the type of system makes CLOVER the best solution in terms of technical performance and characteristics in the case of replacement of the old heat generator. The 4-star certification is the guarantee of raising of the system's efficiency and of the consequent reduction of consumption.

Water diagram

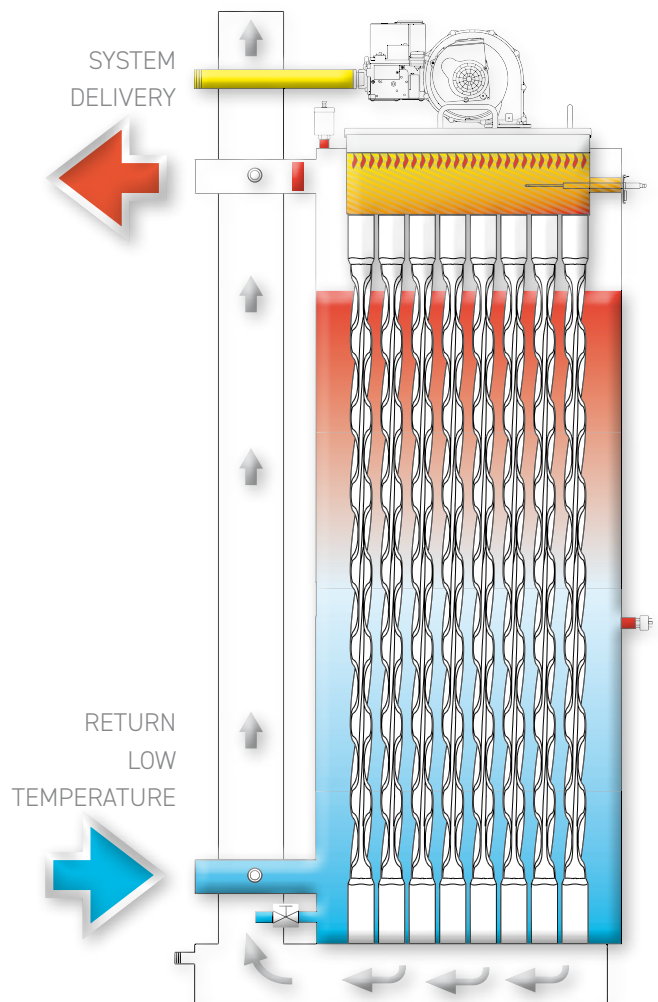

Water content

mod. 70	mod. 125	mod. 160
160 litres	265 litres	380 litres
mod. 220	mod. 320	mod. 450
380 litres	530 litres	561 litres

# CHARACTERISTICS

## PRODUCT BENEFITS

- > **AISI 316 L** stainless steel exchanger with vertical development helical section flue gas pipes
- > Combustion group with emissions in **class 6 according to EN 15502-1**. The modules can work both with Natural Gas and with LPG.
- > Generator protection systems: **Double sensor (delivery and return) system for operation at constant  $\Delta T$**  / Flue gas safety sensor / Water pressure switch with minimum threshold at 0.8 bar
- > Air / Flue Gas Circuit with extraction at the place of installation and **built-in non-return clapet valve** on the extraction unit in order to be able to size the pressurised flue gas manifold
- > **Seasonal efficiency** of the room heating among the highest in its category:  **$\eta_s$  94%**. Combined with the remote modulating control and with the external probe (optional), it reaches the **higher efficiency class A\***
- > The **large volume of water** of the generator means being able to connect the boiler to the system without the need for separation elements and enables a **very high design  $\Delta t$**
- > Management of modules in series with **Self-configuring MASTER/SLAVE system** (which does not require additional controllers)
- > **Setting the switching on and off of the generators** (that can be switched on and off sequentially or can work at the same time in parallel) via the MASTER generator control panel
- > The electronics on the machine are able to manage a **direct two-zone system or a heating zone and a domestic hot water storage tank**. For more complex systems with hybrid heat generation and multiple heating zones, the THETA\* series temperature regulation must be installed.
- > **RANGE RATED** certified generator to adjust the output generated to the needs of the systems, thereby increasing the efficiency of the system and preserving the mechanics of the machine
- > The generators (individual or in series) can be controlled remotely with the THETA\* temperature regulation combined with the HEATAPP gateway via a Wi-Fi network
- > Electronic control of the microprocessor allows the **modulation of 1/5** on the individual generator and of 1/15 for the maximum configuration (3 x 450 modules in series)
- > **Four sturdy floating wheels** fitted as standard to facilitate discharge and mobility in the thermal plant. Positioning feet integrated in the wheel group

## THE PRODUCT IN A NUTSHELL



**REMOTE** Remote control of boiler parameters via remote control



**CLIMATIC** Appliance operating in **climatic regulation** at sliding system temperature (optional external temperature probe)

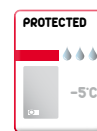

**PROTECTED** Device suitable for operation in a **partially protected place** with minimum temperature of -5°C as standard



**RANGE RATED** "Range rated" certified device in compliance with UNI EN 483



**CASCADE** In **cascade** operation certified by INAIL as a single equivalent generator



**CLASS 6** Minimum polluting emissions (**class 6 according to EN 15502-1**) already in line with the provisions of the ErP directive from 26.09.2018 (NOx emissions <56mg/kWh)



**EASY MAINTENANCE** Appliance specifically designed to be **particularly simple** to install and maintain



**EASY MOVING** Generator equipped with devices to **facilitate handling** during transport and installation



**HEAT EXCHANGER STAINLESS STEEL** **Stainless steel exchanger AISI 316 L patented**



# CLOVER

## THE ART OF BUILDING



**AISI 316L stainless steel** was used to create the exchanger and the condensate collection tank, thereby guaranteeing maximum mechanical resistance against corrosion. The design of the exchanger pipes and their helical development guarantee a greater exchange surface area, an improved heat transmission coefficient between the water and the flue gases and a very low thermal load.

### PREMIX COMBUSTION UNIT

CLOVER is supplied with a total premix combustion unit, with variable speed fan, which operates with **Natural Gas or LPG**. The particular geometry of the front combustion burner and the use of an air/gas mix diffusion grid ensure a perfect division of the thermal load across the entire section of the combustion chamber, protecting the burner and the exchanger against any thermal fluctuations.

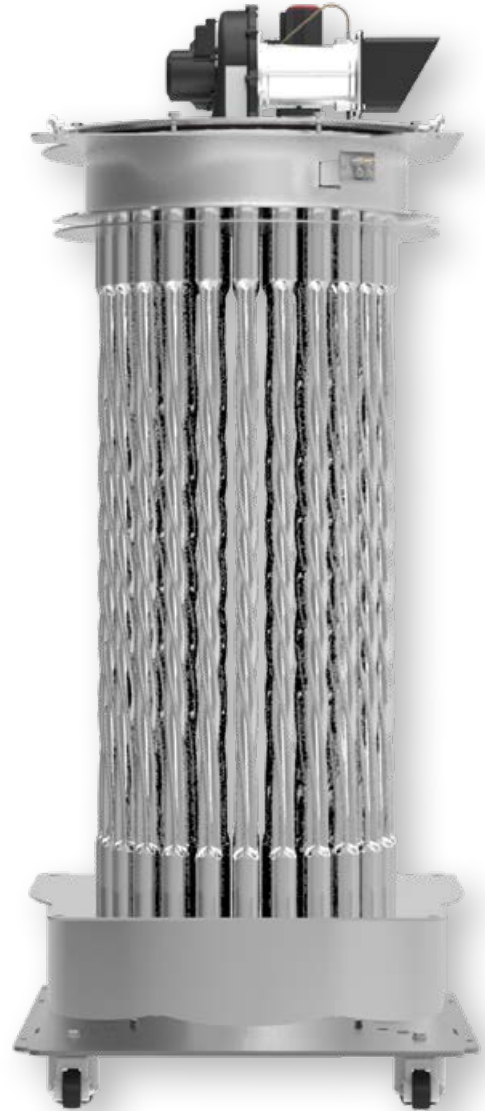

The extremely small vertical configuration of the burner means being able to use the entire extension of the burner, with obvious benefits for the condensation and the stratification in the boiler.

### FLUE GAS ANTI-REFLUX VALVE

A valve with mobile shutter is installed on the premix group fan inlet which prevents the return of flue gases through the boiler in the installation room.

This enables expelling of the pressurised combustion products and consequently being able to size more easily the flue system with reduced diameter pipes compared to the classic depression systems.



# CLOVER

## CONTROL PANEL

Characterised by a large dot-matrix display as well as keys for setting the basic functions of the generator and for selecting the parametrisation menus.

The interface has been designed to facilitate the reading of the parameters and the navigation between the menus both for the USER for the adjustment and setting of the basic functions and for the TECHNICIAN for maintenance and advanced parametrisation.

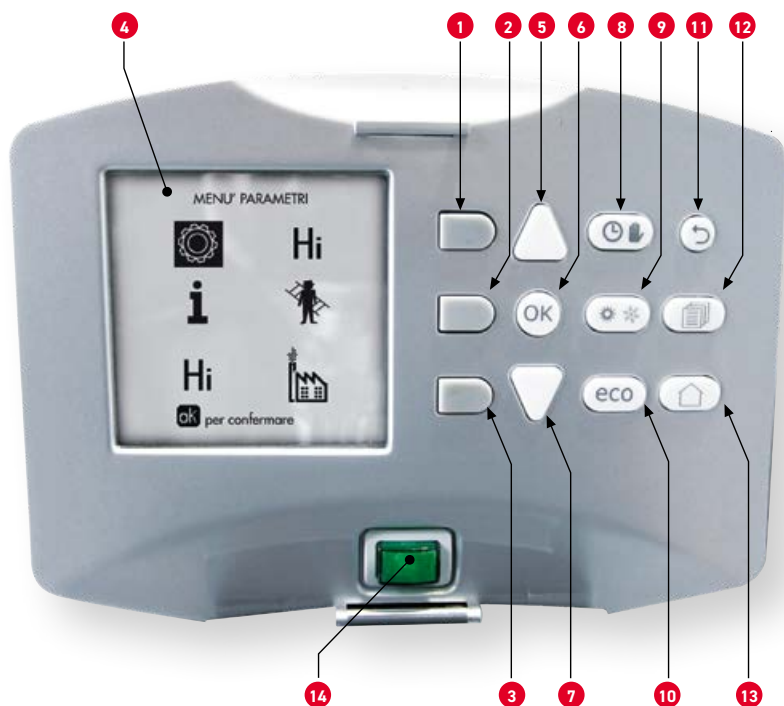

### LEGEND

- 1 Contextual key 1
- 2 Contextual key 2
- 3 Contextual key 3
- 4 Dot-matrix display (main screen example)
- 5 Menu navigation key
- 6 Menu confirm/entry key
- 7 Menu navigation key
- 8 Automatic/Manual heating/DHW operation key
- 9 Summer/Winter mode selection key
- 10 Economy/Comfort mode selection key
- 11 Menu exit key
- 12 Main menu key
- 13 Home key (return to main screen)
- 14 Main switch

**CONTEXTUAL KEYS** (part. 1, 2, 3) can be distinguished by their grey colour, the lack of screen printing and can take on a different meaning depending on the selected menu. It is essential to follow the indication provided by the display (icons and texts). for example, using contextual key 2 (part. 2) it is possible to access device information such as: sensor temperatures, operating powers, etc.

**DIRECT KEYS** (part. 8, 9, 10) always have the same function

### NAVIGATION/MENU KEYS

The navigation/menu keys (part. 5, 6, 7, 11, 12, 13) are used to navigate between the various menus implemented in the control panel

From the main menu of the control panel it is possible to access two distinct levels of parametrisation:

### USER level

Not password protected, it allows the "system manager" to set the operating modes of the single generator or cascade, to best synchronise them with the type of system, according to user needs

### TECHNICIAN level

Password protected, it allows the "authorised technician" to check and possibly modify the thresholds of the individual components, of the generator and of the boiler/system.

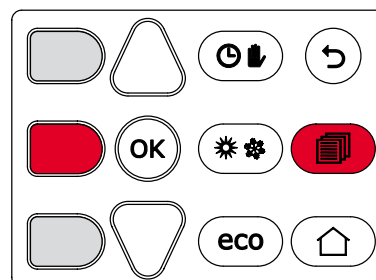
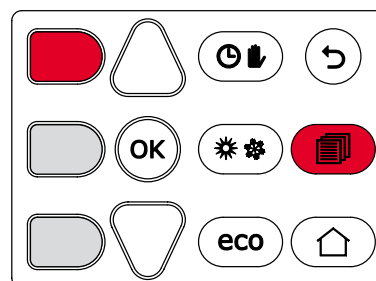

# CHARACTERISTICS

## CONTROL ELECTRONICS

For all its "PROFESSIONAL" series high output condensation heat generators, Lamborghini CaloreClima uses a single electronic platform and the same interface panel that is able to manage the correct operation and safety of the generator, the cascade installation and the main components of a heating system and for the production of domestic hot water.

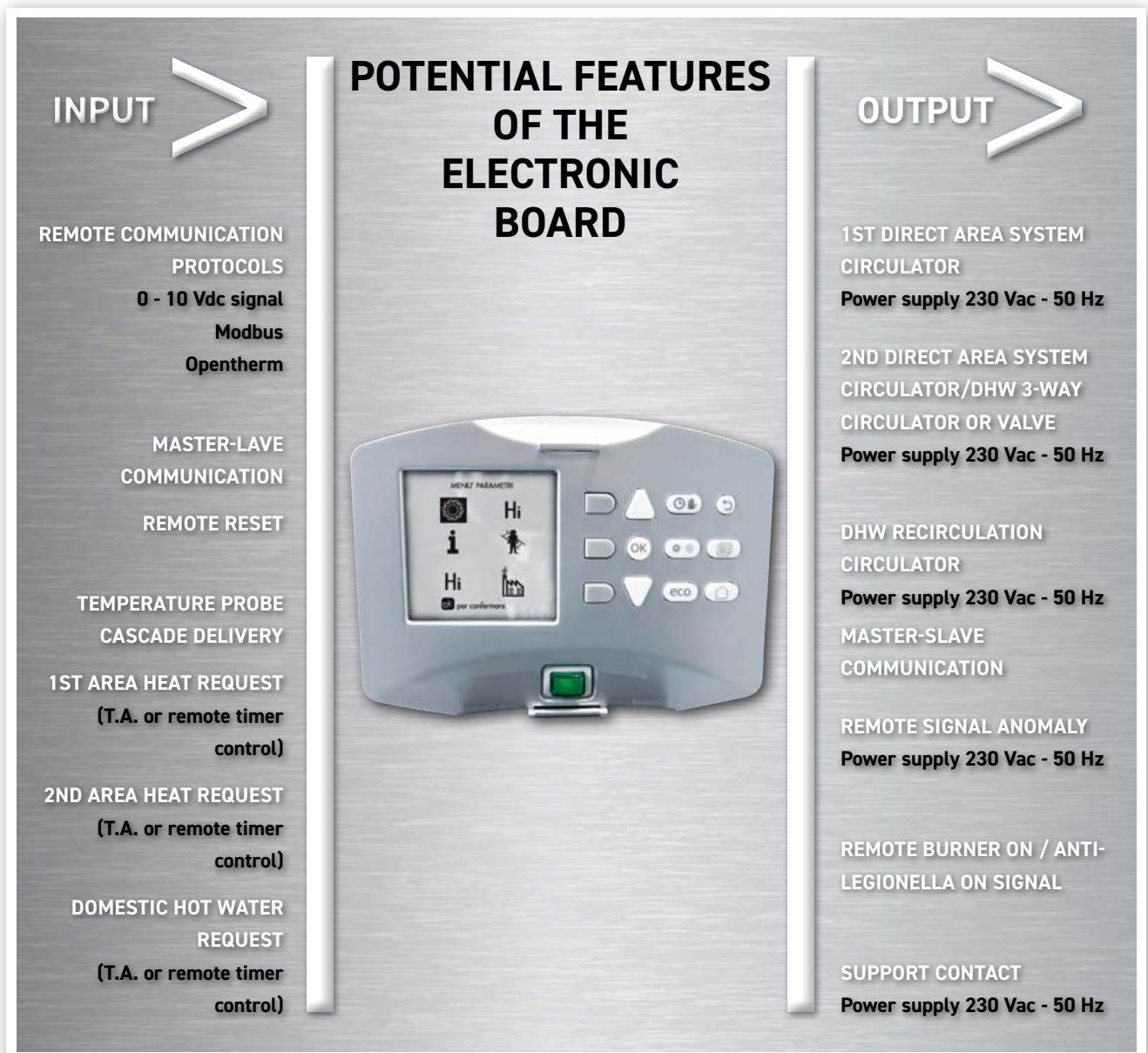

### LEGEND (referred to the diagrams on the next page)

**32** Boiler circulator **72a** 1st zone room thermostat (mixed) **72b** 2nd zone room thermostat (mixed) **72c** 3rd zone room thermostat (direct) **138** External probe **139a** 1st zone remote timer control (mixed) **139b** 2nd zone remote timer control (mixed) **139c** 3rd zone remote timer control (direct) **155** Boiler probe **300** Anti-legionella valve **315a** 1st zone mixing valve **315b** 2nd zone mixing valve (mixed) **317a** 1st zone safety thermostat (mixed) **317b** 2nd zone safety thermostat (mixed) **318a** 1st zone circulator (mixed) **318b** 2nd zone circulator (mixed) **318c** 3rd zone circulator (direct) **319a** 1st zone delivery sensor (mixed) **319b** 2nd zone delivery sensor (mixed) **a** 1st zone (mixed) **b** 2nd zone (mixed) **c** 3rd zone (direct) **d** Boiler circuit **INAIL** Inail safety devices **FZ4 B** Zone control board



# CHARACTERISTICS

## CONTROL ELECTRONICS

In the case of installation of CLOVER in a direct two-zone system (heating and domestic hot water load circuit type), the basic electronics are able to manage the system independently without the need for optional external equipment. On high and low operating temperature mixed systems, the boiler must be combined with the THETA+ temperature regulation module.

### CASE A: REPLACEMENT OF THE EXISTING GENERATOR ON A HIGH TEMPERATURE SYSTEM

Thermal system consisting of a high temperature circuit combined with a storage tank for the domestic hot water. The CLOVER electronic control, besides guaranteeing correct operation of the generator, directly manages each component of the system.

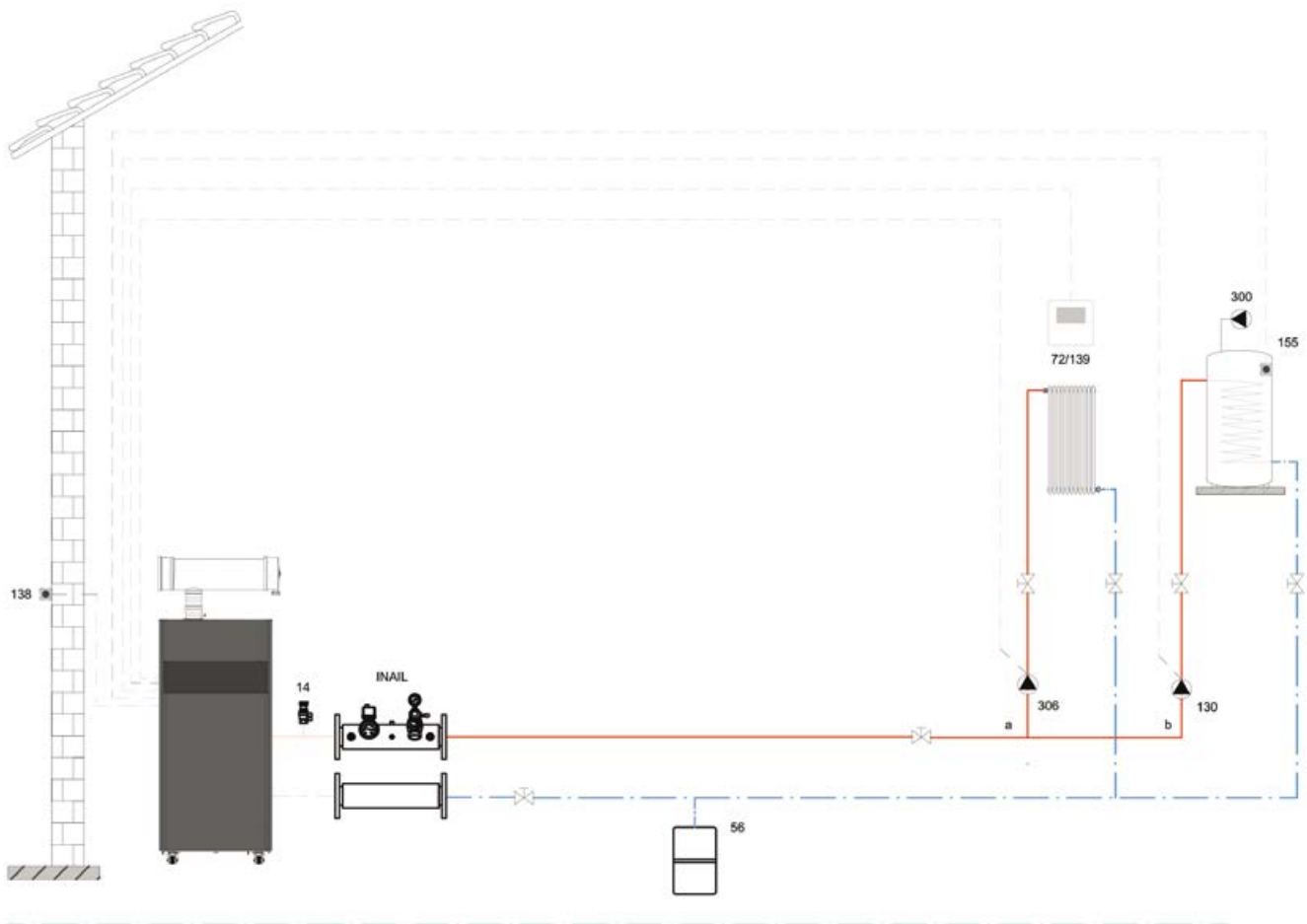

#### LEGEND

14 Safety valve 72/139 Room thermostat/remote timer control 56 Expansion vessel 138 External probe 155 Boiler temperature probe  
130 Boiler circulator 300 Anti-legionella valve 306 System circulator INAIL Inail safety devices a First zone b Boiler circuit - - - - Electrical connections

# CHARACTERISTICS

## CONTROL ELECTRONICS

### CASE B: NEW DESIGN SYSTEM

The heat generator consists of a system with three CLOVER in series. The electronics on board each boiler are able to manage the cascade independently, with the MASTER/SLAVE type self-configuring system.

The distribution system consists of three heating circuits (two mixed at low temperature and one direct at high temperature), a double coil storage tank for the DHW with an integration solar system.

The THETA+ thermal unit, with the aid of room units/sensors (two sensors plus a room unit for remote programming), is able to manage every component of the circuit including the solar system. In the case of systems with a greater number of zones, it is possible to manage up to a max of 10 mixed zones and 5 direct zones, thereby creating a cascade (max 5) of THETA+ thermal units. The zones can be controlled by three RFF type room sensors or by three RS-L type remote room units or by a mix of the two.

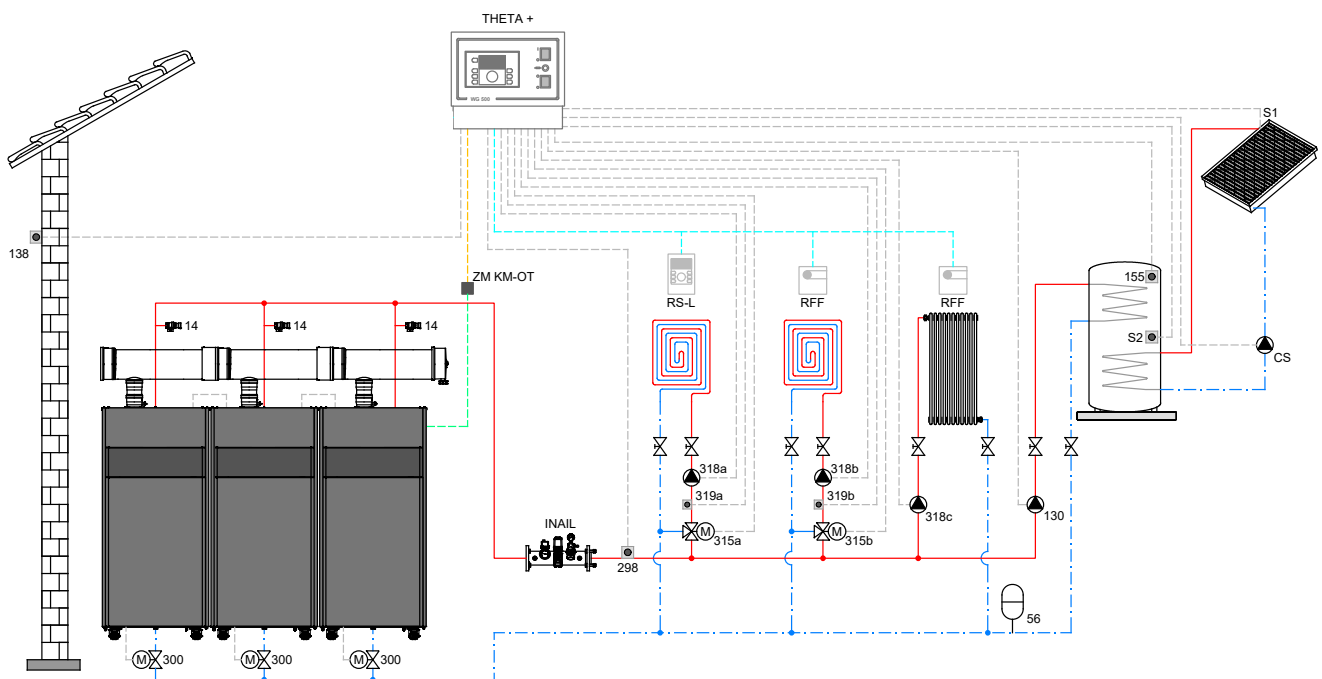

### LEGEND

**THETA+** Central temperature regulation unit and cascade manager installed in the WG500 wall support **ZM KM-OT** Module for cascade management and communication between the generator and the THETA+ unit via Open Therm **RS-L** Room unit **RFF** Room probe **a** Low temperature mixed zone **b** Low temperature mixed zone **c** High temperature direct zone **d** DHW production with double coil storage **298** System delivery manifold probe **14** Safety valve **56** Expansion vessel **300** Butterfly valve **138** External probe **315 a/b** Motorised mixing valve **318 a/b/c** Heating system circulator **319 a/b** Mixed zone delivery probe **155** Boiler probe **130** Domestic hot water storage charging circulator **S1** Solar array delivery probe **S2** Boiler temperature probe **CS** Solar circulator

\*- - - ZM KM-OT \*- - - RS-L / RFF \*- - - OpenTherm

# CHARACTERISTICS

## CONTROL ELECTRONICS

### THETA+

TEMPERATURE REGULATION SYSTEM AND CASCADE MANAGER



Unit for the climatic temperature regulation of heating systems, for the active management of cascade heat generators and the direct control of mono-, two-stage and modulating blown air burners. Class ErP (EU 811/2013) VI.

Each THETA+ control unit is able to manage a thermal system with:

- 2 low temperature mixed zones
- 1 high temperature direct zone
- 1 domestic hot water storage tank
- Thermal solar system, biomass or puffer multi-energy generators with two programmable outputs
- Cascade of thermal generators up to 8 modules

### HEATAPP!+

REMOTE CONTROL SYSTEM OF THE THETA+ REGULATOR



Heatapp!, via a home Internet network, is able to manage, fully remotely, the functions of the THETA+ regulator

The Heatapp! was designed on multiple levels of access in order to be able to profile the various users that need to access the parameters.

The Heatapp! system is not compatible with the RS-L room unit or with the RFF room sensor.

### MODBUS

The Lamborghini CaloreClima generators in the CLOVER line can interface via the Modbus protocol with the devices of a BUILDING MANAGEMENT SYSTEM for the integrated management of the thermal generators and for controlling these remotely.

#### MODBUS CONNECTION TERMINALS

Terminals	Descriptions
39	MODBUS Gnd
40	Rs485+ / MODBUS A
42	RS485- / MODBUS B

#### EXAMPLE OF BOILER CONNECTION ON MODBUS NETWORK

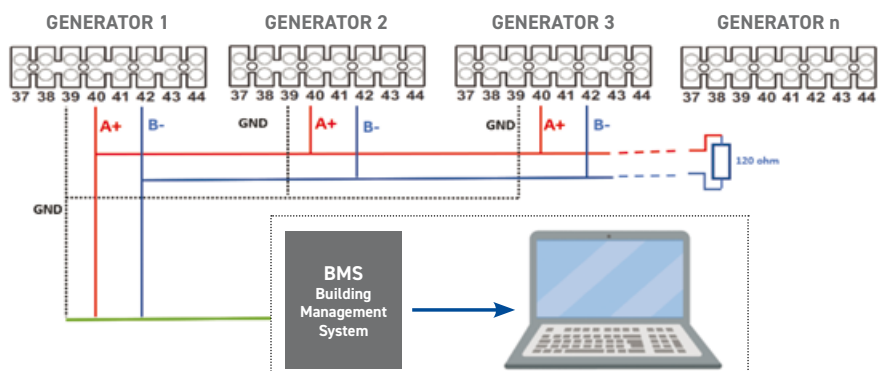

# TECHNICAL DATA

## DIMENSIONS

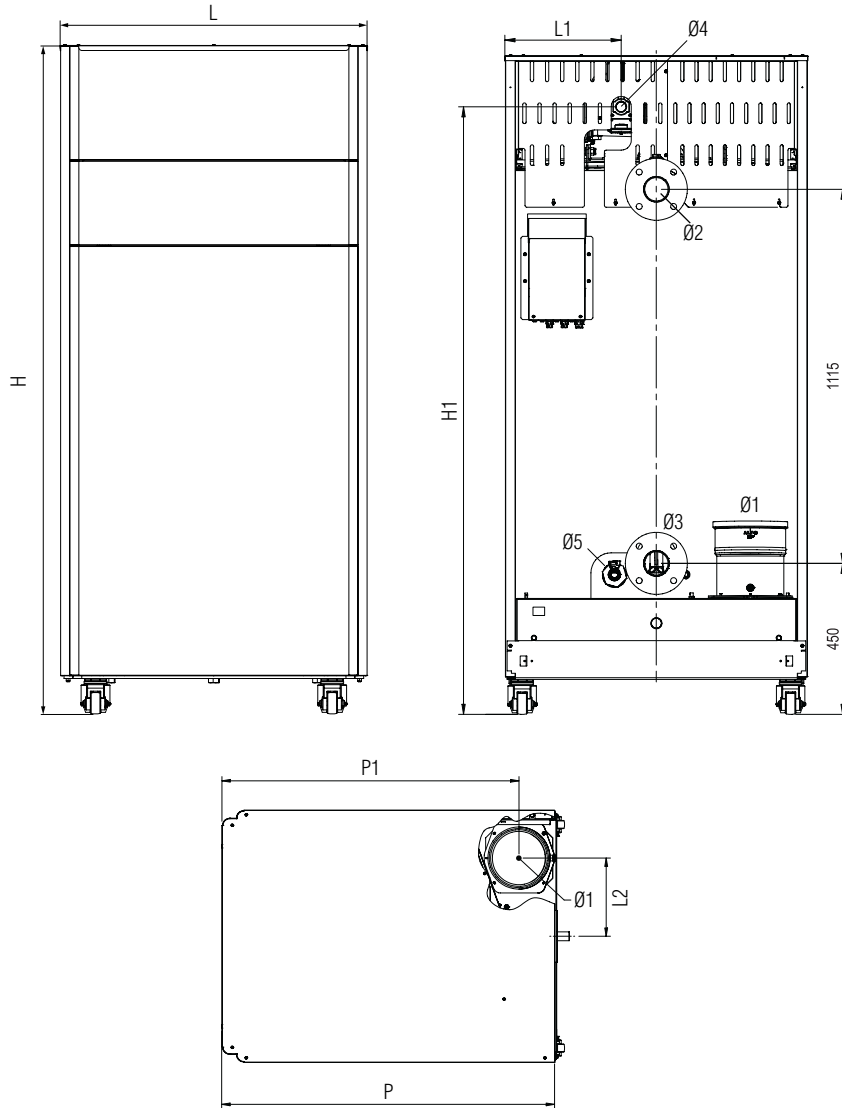

### HYDRAULIC, GAS AND FLUE GAS OUTLET CONNECTIONS

MODEL		70	125	160	220	320	450
$\text{Ø} 1$	Flue gas outlet (mm)	80	100	160	160	200	200
$\text{Ø} 2$	System delivery	1' 1/4	1' 1/4	2'	2'	DN 65	DN 65
$\text{Ø} 3$	System Return	1' 1/4	1' 1/4	2'	2'	DN 65	DN 65
$\text{Ø} 4$	Gas inlet	3/4'	1'	1'	1'	1'	1'
$\text{Ø} 5$	Boiler drain	3/4'	3/4'	3/4'	3/4'	3/4'	3/4'

### PRODUCTS AND DIMENSIONS

ITEMS	L	L1	L2	H	H1	P	P1
	mm	mm	mm	mm	mm	mm	mm
CLOVER 70	540	305	210	1883	1815	730	685
CLOVER 125	660	390	160	1903	1800	880	810
CLOVER 160	780	450	240	1933	1815	1050	950
CLOVER 220	780	300	240	1933	1770	1050	950
CLOVER 320	900	350	280	1963	1810	1190	1060
CLOVER 450	900	345	280	2200	2050	1190	1060

# TECHNICAL DATA

## SUMMARY TABLE

MODEL		70	125	160	220	320	450
ERP Class		A	-	-	-	-	-
Room heating energy efficiency	$\eta_p$ %	94	94	94	94	94	93
<b>Efficiency and performance</b>							
Max. heating thermal input	kW	65.5	116.0	150.0	207.0	299.0	420.0
Min. heating thermal input	kW	14.0	23.0	41.0	41.0	62.0	80.0
Max. heating thermal output (80/60°C)	kW	64.4	114.0	147.0	204.0	294.5	412.7
Min. heating thermal output (80/60°C)	kW	13.7	22.5	40.2	40.2	60.8	78.4
Max. heating thermal output (50/30°C)	kW	69.9	123.9	160.0	221.0	319.3	448.6
Min. heating thermal output (50/30°C)	kW	15.0	24.8	44.2	44.2	66.8	86.2
Pmax efficiency (80/60°C)	%	98.3	98.3	98.4	98.5	98.5	98.3
Pmin efficiency (80/60°C)	%	98.0	98.0	98.0	98.0	98.0	98.0
Pmax efficiency (50/30°C)	%	106.8	106.8	106.8	106.8	106.8	106.8
Pmin efficiency (50/30°C)	%	107.7	107.7	107.7	107.7	107.7	107.7
Efficiency 30% (30°C)	%	109.6	109.6	109.5	109.6	109.6	109.3
NOx class		6	6	6	6	6	6
Max Heating Temperature	°C	90	90	90	90	90	90
Max domestic hot water temperature	°C	70	70	70	70	70	70
ΔT max exchanger	°C	60	60	60	60	60	60
Maximum flue duct head Pmax	pascal	200	150	200	200	200	200
Min / max operating pressure	bar	0.8 - 6	0.8 - 6	0.8 - 6	0.8 - 6	0.8 - 6	0.8 - 6
<b>Structural characteristics</b>							
Water content	litres	160	265	380	380	530	561
Empty weight	Kg	180	280	400	400	500	450
<b>Electrical features</b>							
Supply voltage	V/Hz	230 / 50	230 / 50	230 / 50	230 / 50	230 / 50	230 / 50
Degree of electrical protection	IP	X0D	X0D	X0D	X0D	X0D	X0D
Electric power absorbed	W	105	200	260	260	330	800
<b>Hydraulic and gas connections</b>							
System delivery		1' 1/4	1' 1/4	2'	2'	DN 65	DN 65
System return		1' 1/4	1' 1/4	2'	2'	DN 65	DN 65
Gas inlet		1'	1'	1'	1'	1'	1'
Flue gas outlet $\varnothing$ (mm)		80	100	160	160	200	200
<b>Combustion</b>							
Type of appliance		B23	B23	B23	B23	B23	B23
Combustion efficiency Pmax (80/60°C)	%	98.3	98.3	98.3	98.3	98.3	98.3
Combustion efficiency Pmin (80/60°C)	%	98.7	98.7	98.7	98.7	98.7	98.7
Burner flue duct losses Pmax	%	1.7	1.7	1.7	1.7	1.7	1.7
Burner flue duct losses Pmin	%	1.3	1.3	1.2	1.3	1.3	1.2
Flue gases temperature Pmax / Pmin (80/60°C)	°C	68 / 60	66 / 60	67 / 61	67 / 61	67 / 61	67 / 61
Flue gases temperature Pmax / Pmin (50/30°C)	°C	43 / 32	43 / 32	45 / 31	45 / 31	45 / 31	45 / 31
Flue gas flow rate Pmax	kg/h	107.1	189.6	244.8	338.4	488.8	672
Flue gas flow rate Pmin	kg/h	23.3	39.9	72	71.1	107.5	133
CO <sub>2</sub> Pmax / Pmin	%	9.3 / 9.1	9.3 / 8.7	9.3 / 8.7	9.3 / 8.7	9.3 / 8.7	9.0 / 8.5
CO O <sub>2</sub> =0% Pmax	mg/kWh	17	30	15	40	35	13
CO O <sub>2</sub> =0% Pmin	mg/kWh	1	2	1	2	3	1
NOx O <sub>2</sub> =0% Pmax	mg/kWh	69.7	50	78	44	41	148
NOx O <sub>2</sub> =0% Pmin	mg/kWh	13.3	10	12	9	10	17
NOx O <sub>2</sub> =0% weighted	mg/kWh	18	17	22	22	20	53
Internal sound power level LWA	dB	58	62	72	72	76	77

# CASCADE INSTALLATION

## INAIL CERTIFICATION



Lamborghini CaloreClima has obtained the certification **from INAIL attesting the equivalence of a single generator for 16 types of modular installations** composed of two or three generators.

It is in fact possible to connect in cascade from a minimum of two 70kW generators up to a maximum of three 450 kW generators, with the combinations shown in the table.

For all these configurations, the Company guarantees the correct operation and supplies all the hydraulic and gas accessories for the flue gas manifold and the INAIL safety kit, necessary for implementing the "cascade".

COMBINATIONS OF 2 GENERATORS IN SERIES - CERTIFIED BY INAIL				
THERMAL OUTPUT (50/30°C)	MODELS CLOVER		SERIES MODULATION P <sub>MIN</sub> /P <sub>MAX</sub> (50/30°C)	
	kW	1°	2°	MODULATION RATIO
139.8	70	70	15.0/139.8	1 / 9
194.9	70	125	15.0 / 194.9	1 / 13
250.0	125	125	24.8 / 250.0	1 / 10
285.0	125	160	24.8 / 285.0	1 / 11
320.0	160	160	44.2 / 320.0	1 / 7
380.0	160	220	44.2 / 380.0	1 / 9
440.0	220	220	44.2 / 440.0	1 / 10
540.0	220	320	44.2 / 540.0	1 / 12
640.0	320	320	66.8 / 640.0	1 / 10
818.6	320	450	66.8 / 768.6	1 / 11
897.2	450	450	86.2 / 897.2	1 / 10

COMBINATIONS OF 3 GENERATORS IN SERIES - CERTIFIED BY INAIL					
THERMAL OUTPUT (50/30°C)	MODELS CLOVER			SERIES MODULATION P <sub>MIN</sub> /P <sub>MAX</sub> (50/30°C)	
	kW	1°	2°	3°	MODULATION RATIO
209.7	70	70	70	15.0 / 209.7	1 / 14
264.8	70	70	125	15.0 / 264.8	1 / 18
319.9	70	125	125	15.0 / 319.9	1 / 21
375.0	125	125	125	24.8 / 375.0	1 / 15
410.0	125	125	160	24.8 / 410.0	1 / 16
445.0	125	160	160	24.8 / 445.0	1 / 18
480.0	160	160	160	44.2 / 480.0	1 / 11
540.0	160	160	220	44.2 / 540.0	1 / 12
600.0	160	220	220	44.2 / 600.0	1 / 14
660.0	220	220	220	44.2 / 660.0	1 / 15
760.0	220	220	320	44.2 / 760.0	1 / 17
860.0	220	320	320	44.2 / 860.0	1 / 19
960.0	320	320	320	66.8 / 960.0	1 / 14
1088.6	320	320	450	66.8 / 1088.6	1 / 16
1217.2	320	450	450	66.8 / 1217.2	1 / 18
1345.8	450	450	450	86.2 / 1345.8	1 / 15

# CASCADE INSTALLATION

## PRACTICAL AND INTELLIGENT

Every detail has been designed to facilitate the installations in cascade.

- 1 The hydraulic connections have been positioned at the same heights in order to promote their connection to the system's delivery and return manifolds.
- 2 The "satellite" flue gas outlet with respect to the body of the generator and the anti-reflux shutter positioned directly on the fan facilitate the sizing and creation of the flue gas manifold (pressurised).
- 3 The CLOVER range is combined with a complete series of accessories for multiple combinations in series of two or three generators, until reaching a maximum output of 1350 kW.
- 4 The electronics fitted as standard were designed to be able to independently manage the dynamics of multiple generators in cascade, with MASTER-SLAVE logics, up to a maximum number of 6.
- 5 By parameterising the cascade MASTER board, it is possible to set the switching on and off sequence of the various modules and the rotation of the switching on sequence so as to distribute the number of hours of operation evenly.
- 6 Each complete configuration of flue gas, hydraulic and gas accessories has been subjected to INAIL approval and therefore certified as a "Single Generator".

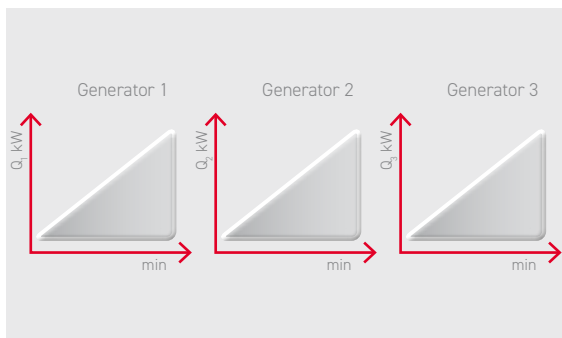

### Parallel operation

The "parallel" operation of the modules entails switching on, modulation of the output and switching off of the burners simultaneously. This solution offers maximum efficiency of the system as the greatest number of generators on at the lowest output guarantees the maximum level of condensation. Instead, the system output modulation range is limited.

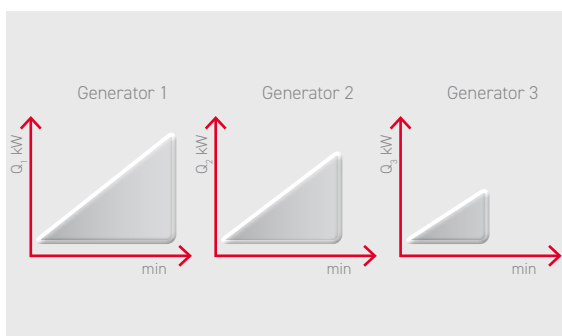

### Sequential operation

Sequential switching on and modulation of the output of the burners guarantees a wide range of modulation which spans from the minimum output of a single generator to the maximum sum of outputs of all the burners when on.

This makes the system more flexible with respect to the thermal needs of the system but at the expense of the loss of a certain degree of energy efficiency.

# CASCADE INSTALLATION

## FLUE GAS MANIFOLD ACCESSORIES

### HIGH OUTPUT FLUE GAS MANIFOLDS

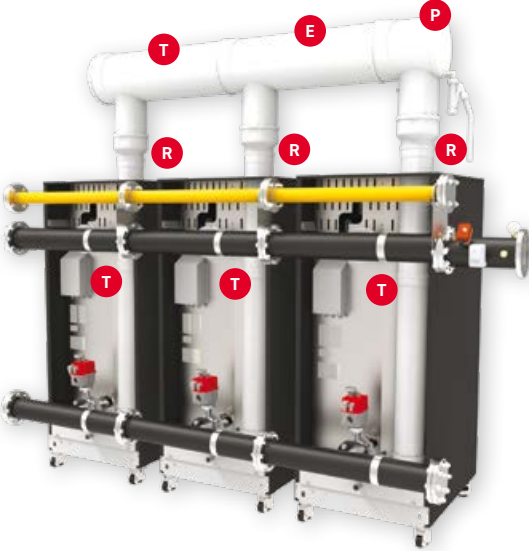

### MEDIUM OUTPUT FLUE GAS MANIFOLD

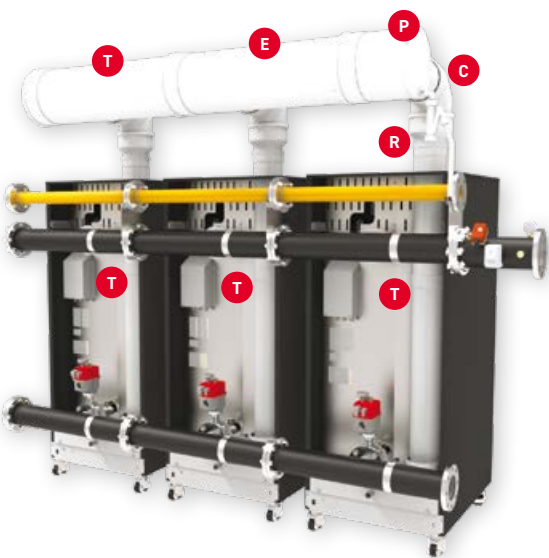

### LOW OUTPUT FLUE GAS MANIFOLD

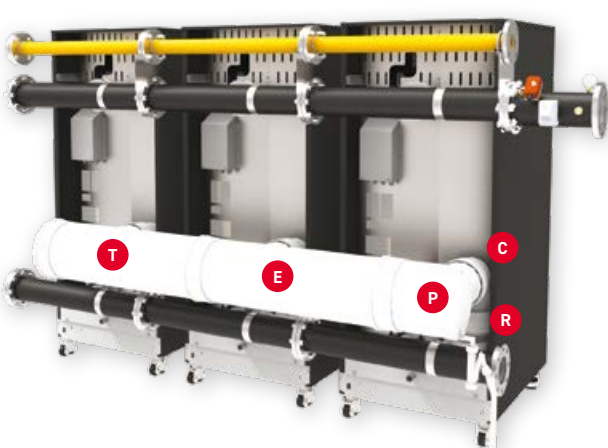

THE RANGE OF FLUE GAS ACCESSORIES WAS DESIGNED TO BE ABLE TO CREATE THE DUCT TO VARIOUS HEIGHTS AND WITH OUTPUT TO THE RIGHT AND LEFT. THIS CHOICE, IN THE CASE OF REPLACEMENT OF AN OLD GENERATOR, FACILITATES CONNECTION WITH THE INLET OF THE EXISTING FLUE DUCT

P		flue gas manifold closure end	160 mm	041066X0
			200 mm	041068X0
			300 mm	041070X0
E		flue gas manifold	160 mm	041067X0
			200 mm	041069X0
			300 mm	041071X0
T		M/F flue gas pipe in PPS length 500 mm	100 mm	041072X0
			160 mm	041074X0
			200 mm	041076X0
T		M/F flue gas pipe in PPS length 1000 mm	100 mm	041073X0
			160 mm	041018X0
			200 mm	041062X0
T		elbow 90° M/F in PPS	300 mm	041063X0
			100 mm	041077X0
			160 mm	041015X0
R		reducer M/F in PPS	200 mm	041060X0
			160 mm	041061X0
			80-100 mm	041078X0
R		reducer M/F in PPS	100-160 mm	041079X0
			160-200 mm	041080X0



**FLUE GAS ACCESSORIES NECESSARY FOR THE CORRECT INSTALLATION OF 2 CLOVER GENERATORS IN SERIES**

THERMAL OUTPUT (50/30°C) KW	MODULES CLOVER			FLUE GAS EXPULSION	P	P	P	E	E	E	T	T	T	T	T	T	C	C	C	R	R	R		
	1	2	3		Start flue gas manifold F 300 mm	Start flue gas manifold F 200 mm	Start flue gas manifold F 160 mm	Flue gas manifold F 300 mm	Flue gas manifold F 200 mm	Flue gas manifold F 160 mm	Pipe f 200 M-F L 1000 mm PPS	Pipe f 200 M-F L 500 mm PPS	Pipe f 160 M-F L 1000 mm PPS	Pipe f 160 M-F L 500 mm PPS	Pipe f 100 M-F L 1000 mm PPS	Pipe f 100 M-F L 500 mm PPS	Elbow 90° F 200 M-F PPS	Elbow 90° F 160 M-F PPS	Elbow 90° F 100 M-F PPS	Reduction F 160-200 mm M-F PPS	Reduction F 100-160 mm M-F PPS	Reduction F 80-100 mm M-F PPS		
	nr.	nr.	nr.		nr.	nr.	nr.	nr.	nr.	nr.	nr.	nr.	nr.	nr.	nr.	nr.	nr.	nr.	nr.	nr.	nr.	nr.	nr.	
139.8	70	70	-	Low			1			1									2			2		
				Medium			1			1					2	2			2					2
				High			1			1					2	2								
194.9	70	125	-	Low			1			1									2			1		
				Medium			1			1					2	2			2					1
				High			1			1					2	2								
250.0	125	125	-	Low			1			1									2					
				Medium			1			1					2	2			2					
				High			1			1					2	2								
285.0	125	160	-	Low		1			1								2				1	2		
				Medium		1			1				1	2	1	1		2				1	2	
				High		1			1				1	2	1	1						1	2	
320.0	160	160	-	Low		1			1								2					1		
				Medium		1			1				2	2			2						1	
				High		1			1				2	2										1
380.0	160	220	-	Low		1			1								2							
				Medium		1			1				2	2			2							
				High		1			1				2	2										
440.0	220	220	-	Low		1			1								2							
				Medium		1			1				2	2			2							
				High		1			1				2	2										
540.0	220	320	-	Low	1				1							2				1				
				Medium	1				1			1	1		3		2				1			
				High	1				1			1	1		3						1			
640.0	320	320	-	Low	1				1							2								
				Medium	1				1			2	2				2							
				High	1				1			2	2											
818.6	320	450	-	Low	1				1							2								
				Medium	1				1			4				2								
				High	1				1			4												
897.2	450	450	-	Low	1				1						2									
				Medium	1				1			4	4			2								
				High	1				1			4	4											



# CASCADE INSTALLATION



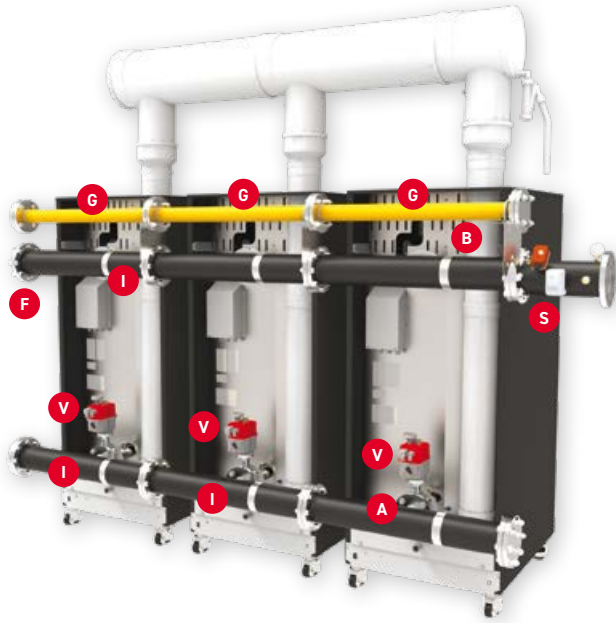















## HYDRAULIC AND GAS ACCESSORIES



THE HYDRAULIC AND GAS ACCESSORIES ARE DESIGNED TO FACILITATE ASSEMBLY AND ARE USED TO CONNECT THE SERIES TO THE SYSTEMS WITH INDEPENDENT OUTPUTS ON THE RIGHT OR LEFT TO MAKE THE REPLACEMENT OF OLD GENERATORS EASIER.

G		gas manifold	1' 1/2-1'	042050X0
			2' -1'	042051X0
			2' 1/2-1'	042052X0
I		hydraulic manifold	DN50-1 1/2'	042053X0
			DN65-2'	042054X0
			DN100-DN65	042055X0
S		Inail holding stub (complete with Instruments)	DN50	042056X0
			DN65	042057X0
			DN100	042058X0
V		motorised butterfly valve, DN 50 powered by 230V - 50Hz for model 70 and 125	052000X0	
			motorised butterfly valve, DN 65 powered by 230V - 50Hz for model 160, 220 and 320	052001X0
A		flange - sleeve	DN50 - 1'1/4	042065X0
			DN65 - 2'	042066X0
A		reduction nipple M - F	2' - 1'1/4	042064X0
B		union F - F	1' 1/4	042062X0
			2'	042063X0
F		flange kit (including nuts, bolts and gaskets)	DN50	042059X0
			DN65	042060X0
			DN100	042061X0

**HYDRAULIC AND GAS ACCESSORIES NECESSARY FOR THE CORRECT INSTALLATION OF 2 CLOVER GENERATORS IN SERIES**

				     															
				     															
				     															
THER- MAL OUTPUT (50/30°C) KW	MODULES CLOVER			MANIFOLD	042050X0	042051X0	042052X0	042053X0	042054X0	042055X0	042059X0	042060X0	042061X0	042062X0	042063X0	042064X0	042065X0	042066X0	
	1	2	3		nr.	nr.	nr.	nr.	nr.	nr.	nr.	nr.	nr.	nr.	nr.	nr.	nr.	nr.	nr.
139.8	70	70	-	Gas	2														
				Delivery			2				1			2					
194.9	70	125	-	Return				2			1						4		
				Gas	2														
250.0	125	125	-	Delivery				2			1			2					
				Return				2			1								4
285.0	125	160	-	Gas		2													
				Delivery					2			1			2	1			
320.0	160	160	-	Return					2		1								4
				Gas		2													
380.0	160	220	-	Delivery					2		1			2					
				Return					2			1							
440.0	220	220	-	Gas		2													
				Delivery						2			1			2			
540.0	220	320	-	Return					2				1						1
				Gas			2							1					
640.0	320	320	-	Delivery			2				1								
				Return					2				1						
818.6	320	450	-	Gas			2					1							
				Delivery						2				1					
897.2	450	450	-	Return					2			1							
				Gas			3						1						
				Delivery					3			1							
				Return					3			1							

**HYDRAULIC AND GAS ACCESSORIES NECESSARY FOR THE CORRECT INSTALLATION OF 3 CLOVER GENERATORS IN SERIES**

					G	G	G	I	I	I	F	F	F	B	B	A	A	A			
					Gas manifold 1" 1/2 - 1"	Gas manifold 2" - 1"	Gas manifold 2" 1/2 - 1"	Hydraulic manifold DN50 - 2"	Hydraulic manifold DN65 - 2"	Hydraulic manifold DN100 - DN65	Flange kit DN50	Flange kit DN65	Flange kit DN100	Union F-F 1"1/4	Union F-F 2"	Reduction nipple 2" - 1"1/2 M-F	Flange DN50 - sleeve 1"1/4	Flange DN65 - sleeve 2"			
THERMAL OUTPUT (50/30°C) KW	MODULES CLOVER			MANIFOLD	042050X0	042051X0	042052X0	042053X0	042054X0	042055X0	042059X0	042060X0	042061X0	042062X0	042063X0	042064X0	042065X0	042066X0			
	1	2	3		nr.	nr.	nr.	nr.	nr.	nr.	nr.	nr.	nr.	nr.	nr.	nr.	nr.	nr.	nr.		
209.7	70	70	70	Gas	3																
				Delivery			3				1			3							
264.8	70	70	125	Gas	3																
				Delivery			3				1		3								
319.9	70	125	125	Gas	3																
				Delivery			3				1		3								
375.0	125	125	125	Gas		3															
				Delivery					3			1		3	3						
410.0	125	125	160	Gas		3															
				Delivery					3			1		3	2						
445.0	125	160	160	Gas		3															
				Delivery					3			1		3	2						
480.0	160	160	160	Gas			3					1									
				Delivery						3				1						3	
540.0	160	160	220	Gas			3					1									
				Delivery						3				1						3	
600.0	160	220	220	Gas			3					1									
				Delivery						3				1						3	
660.0	220	220	220	Gas			3					1									
				Delivery						3				1						3	
760.0	220	220	320	Gas			3					1									
				Delivery						3				1						2	
860.0	320	320	220	Gas			3					1									
				Delivery						3				1						1	
960.0	320	320	320	Gas			3					1									
				Delivery						3				1						1	
1088.6	320	320	450	Gas			3					1									
				Delivery						3				1						1	
1217.2	320	450	450	Gas			3					1									
				Delivery						3				1						1	
1345.8	450	450	450	Gas			3					1									
				Delivery						3				1						1	







The illustrations and data provided are indicative. Lamborghini CaloreClima reserves the right to make any changes deemed to be most appropriate for the improvement of the product or of the service offered without being obliged to give prior notice.

The images in this catalogue are under copyright owned by Lamborghini CaloreClima.