



Idola M 3.2 22T-30T

Reversible heat pump for outdoor installation with DC inverter compressor



- This series of air-water heat pumps meets the needs of winter and summer air conditioning of residential and commercial installations of medium power.
- All units are suitable for outdoor installation and being able to produce water up to 60°C may be employed in systems with radiant floor, fancoils, radiators and for the indirect production of domestic hot water (DHW) via an external boiler (not provided).
- The units are characterized by the use of a DC inverter compressor that allows you to modulate the capacity from 30 to 120% of the rated capacity and are complete with a hydronic kit including all the essential components for a quick and safe installation.
- The units are characterized by high energy efficiency and low noise level and they can be used as the sole generator of the system or integrated with other energy sources such as backup electric heaters or boiler.
- All units are supplied with temperature probe (supplied as standard, assembled by the installer) for domestic hot water tank (DHW) and with external air temperature probe (already installed on the unit) to realize the climatic control in heating and cooling modes.
- All the units are accurately built and individually tested in the factory. The installation only requires the electrical and hydraulic connections.



CASCADE

Can be installed in multiple “**cascade**” configuration with a “**MASTER**” unit (directly managed by the controller) **up to 5 “SLAVE”** units, also different in their output power



R32

New Heat Pump in R32, eco-friendly refrigerant with low GWP.

Up to 75% less CO2 equivalent emissions in the environment with respect to machines in R410a

Code	Model
2CP000QL	IDOLA M 3.2 22T
2CP000RL	IDOLA M 3.2 26T
2CP000SL	IDOLA M 3.2 30T

THE CONTROL SYSTEM

- The user interface consists of a wired remote controller (5 wires, max length 50 m from the unit) with menu in 11 languages which allows the management of
- **HEATING AND COOLING SYSTEM**, where the heat pump is the sole energy source. The unit, if activated in heat or cool mode, works by modulating the frequency of the compressor to maintain the temperature of the produced water to the setpoint value set by the controller. Through parameter you can use the remote controller (eg. For single-zone systems) as a room thermostat.
- **DOMESTIC HOT WATER PRODUCTION (DHW)**. The unit is activated in a heat mode to keep the temperature of a DHW tank (not supplied) to the setpoint value. It requires a 3-way diverter valve (not supplied) and a temperature sensor (T5 probe, L = 10m, provided) to be inserted into one well of the DHW tank
- **ADDITIONAL SOURCES OF ENERGY** (boiler or electrical heater). Depending on the parameters set, these sources can be activated in integration or replacement of the heat pump when the system is used for space heating or for DHW production. The controller also activate additional energy sources in case the heat pump is not working
- **ELECTRIC HEATER OF THE DHW TANK**. The controller can manage the activation of an electric heater inserted in the DHW tank as a heat integration to the heat pump, for disinfecting function, or as a source of energy reserve for DHW production in case the heat pump is not working.
- **FAST DHW**. This function can be activated manually and it allows you to give priority to DHW production by activating all energy sources (heat pumps, electric heaters, boiler) available for DHW heating to bring in the shortest time possible the DHW tank to the setpoint required.
- **DISINFECT FUNCTION**. You can set from the controller weekly cycles for disinfecting the water in the DhW tank. In order to successfully execute these cycles, the heat pump must be integrated with DHW electric heater or boiler.
- **SILENT MODE**. If active it allows a reduction of the maximum frequency of the compressor and of the fan speed in order to reduce the noise emitted and the power absorbed by the unit. There are 2 levels of silencing. Through time programming, you can define for 2 daily time bands the desired silent level (eg. during the night).
- **ON / OFF** using an external contact. The unit can be turned on and off (eg. thermostat / remote switch) via an external contact: in this case the unit will operate in the mode set by the controller keyboard.
- **HEAT / COOL** via external contacts. The unit can be activated in heat or cool mode via two external contacts (eg. thermostat that manages the heat and cool demand / remote switch).
- **ECO MODE**. For heating mode it is possible to define daily time band and corresponding set point for ECO mode
- **WEEKLY SCHEDULING**. It allows a scheduling of 6 time bands for each day of the week: for each time band it is possible to define the mode (COOL / HEAT / DHW) and the required setpoint.
- **ANTIFREEZE PROTECTION**. Guaranteed for outdoor air temperature down to -20°C, thanks to the management of the electronic board of the unit which allows you to heat water using antifreeze heater (standard on the plate heat exchanger), the heat pump itself working in heating mode and the electric booster (if installed).
- **CASCADE FUNCTION** up to 6 units can be controlled together in cascade mode (1 master unit, 5 slave units), with only one remote controller connected to the master unit. The master unit can be dedicated to the production of DHW (domestic hot water). In case of failure of a slave unit, all other units can operate normally.
- **MANAGEMENT OF UP TO 2 SYSTEM ZONES (1 MIXED AND 1 DIRECT)**. The unit is able to manage the pumps (not supplied) for both zones and, for the mixed zone only, the mixing valve (not supplied) and the water delivery temperature probe (available as an accessory).
- **PHOTOVOLTAIC INPUT AND SMART GRID INPUT**. The unit is equipped with 2 digital inputs for the management of an input from a photovoltaic system and from the electricity grid. Working logic:

- if the photovoltaic input is closed, the unit turns on DHW mode with DHW setpoint=70°C and (if available) the electrical heater of DHW tank will be turned on. The unit operates in cooling/heating mode as the normal logic.
- If the photovoltaic input is open and smart grid input is closed, the unit operates normally.
- If the photovoltaic input is open and smart grid input is open, the unit turns off DHW mode and can operate in cooling/heating mode for a defined period (settable via parameter) then will be turned off.
- **CURRENT INPUT LIMITATION BY PARAMETER.**
- **REMOTE CONTROL OF THE UNIT VIA APP** (available for IOS and Android).
- **DETAILED ALARMS DIAGNOSTICS WITH ALARMS HISTORY.**
- **DISPLAY OF ALL OPERATING PARAMETERS.**

REFRIGERANT CIRCUIT

- Contained in a compartment protected from the air flow to simplify the maintenance operations, is equipped with 3-speed electronic circulator (brushless DC motor), water flow switch, automatic air vent, water manometer, expansion vessel, safety valve, Y water filter (supplied as standard, assembled by the installer).
- The plate heat exchanger and all the hydraulic pipes are thermally insulated to avoid the formation of condensation and reduce heat loss.

HYDRAULIC CIRCUIT

- Contained in a compartment protected from the air flow to simplify the maintenance operations, is equipped with 3-speed electronic circulator (brushless DC motor), water flow switch, automatic air vent, water manometer, expansion vessel, safety valve, Y water filter (supplied as standard, assembled by the installer).
- The plate heat exchanger and all the hydraulic pipes are thermally insulated to avoid the formation of condensation and reduce heat loss.

ACCESSORIES

- **WATER TEMPERATURE PROBE** The temperature probe can be connected to perform the functions T1 / Tbt1 / Tbt2 / T5 / Tw2 / Tsolar (for more details refer to the installation and user manual of the unit).
- **RUBBER ANTIVIBRATION DAMPERS**

CONTROL THROUGH CLIMA CONTROL DISPLAY (REM CC) SUPPLIED AS PER STANDARD



Technical data

GENERAL DATA		22T		26T		30T	
Seasonal space heating energy efficiency class / medium temperature (water at 55°C)	(Class G - A ⁺⁺)	A⁺⁺	126	A⁺	123	A⁺	123
Seasonal space heating energy efficiency class / low temperature (water outlet at 35°C)	(Class G - A ⁺⁺)	A⁺⁺⁺	178	A⁺⁺⁺	177	A⁺⁺	165
Power supply	V-ph-Hz	380/415-3-50					
SCOP low temperature (water outlet at 35°C)	W/W	4,53		4,50		4,21	
SCOP medium temperature (water at 55°C)	W/W	3,23		3,15		3,15	
SEER water at 7°C	W/W	4,70		4,66		4,49	
SEER water at 18°C	W/W	5,67		5,88		5,71	
Power supply	-	Twin Rotary DC					
Compressor type	n°	1					
N° compressors / N° refrigerant circuits	n°	1					
Plant side heat exchanger type	-	stainless steel brazed plates					
Source side heat exchanger type		finned coil					
Fans type	-	DC axial					
N° fans	n°	2					
Expansion tank volume	l	8					
Water safety valve set	bar	3					
Hydraulic fittings	"	1-1/4"					
Minimum water content onf the system	l	40					
DHW boiler - minimum surface of the coil (minimum / recommended)	steel	m²	3,5				
	enamel	m²	5				
Refrigerant type	type	R32					
GWP	kg-CO ₂ eq.	675					
Refrigerant charge	kg	5					
	t-CO ₂ eq.	3,38					
Control type	-	remote wired					
SWL - Sound power level Cooling *	A7W35	dB(A)	73	75	77		
	A7W55	dB(A)	73	75	77		
	Sil. 1	dB(A)	69	71	73		
	Sil. 2	dB(A)	66	68	69		
SWL - Sound power level Heating *	A35W18	dB(A)	73	75	75		
	A35W7	dB(A)	73	75	75		
	Sil. 1	dB(A)	69	71	73		
	Sil. 2	dB(A)	66	68	69		
Max. current input	A	25	27	29			

* : **SWL** = Sound power levels, with reference to 1x10⁻¹² W with unit operating in conditions:

A7W35 = source : air in 7°C d.b. 6°C w.b. / plant : water in 30°C out 35°C

A7W55 = source : air in 7°C d.b. 6°C w.b. / plant : water in 47°C out 55°C

A35W18 = source : air in 35°C d.b. / plant : water in 23°C out 18°C

A35W7 = source : air in 35°C d.b. / plant : water in 12°C out 7°C

Sil. 1 = if silent level 1 active in heating / cooling mode

Sil. 2 = if silent level 2 active in heating / cooling mode

The Total sound power level in dB(A) measured in compliance with ISO 9614 standards.

Performances

PERFORMANCES				22T	26T	30T
A7W35	Heating capacity	kW	nom	22	26	30
	Power input	kW	nom	5	6,37	8,03
	COP	W/W		4,4	4,08	3,75
	Water flow rate	l/h		3784	4472	5160
	Available static pressure	kPa		92	78	60
A7W45	Heating capacity	kW	nom	22	26	30
	Power input	kW	nom	6,47	8,39	10,3
	COP	W/W		3,4	3,1	2,9
	Water flow rate	l/h		3784	4472	5160
	Available static pressure	kPa		92	78	60
A7W55	Heating capacity	kW	nom	22	26	30
	Power input	kW	nom	8,3	10,6	13
	COP	W/W		2,65	2,45	2,3
	Water flow rate	l/h		2365	2795	3225
	Available static pressure	kPa		106	103	99
A35W18	Cooling capacity	kW	nom	21	26	30
	Power input	kW	nom	7,12	9,63	12,8
	EER	W/W		2,95	2,7	2,35
	Water flow rate	l/h		3612	4472	5160
	Available static pressure	kPa		95	78	60
A35W7	Cooling capacity	kW	nom	23	27	31
	Power input	kW	nom	5	6,28	7,76
	EER	W/W		4,6	4,3	4
	Water flow rate	l/h		3956	4644	5332
	Available static pressure	kPa		90	74	54

The values are referred to units without options and accessories. Data declared according to **EN 14511**: **EER** (Energy Efficiency Ratio) = ratio of the total cooling capacity to the effective power input of the unit **COP** (Coefficient Of Performance) = ratio of the total heating capacity to the effective power input of the unit **A7W35** = source : air in 7°C d.b. 6°C w.b. / plant : water in 30°C out 35°C **A7W45** = source : air in 7°C d.b. 6°C w.b. / plant : water in 40°C out 45°C **A7W55** = source : air in 7°C d.b. 6°C w.b. / plant : water in 47°C out 55°C **A35W18** = source : air in 35°C d.b. / plant : water in 23°C out 18°C **A35W7** = source : air in 35°C d.b. / plant : water in 12°C out 7°C

Dimensions

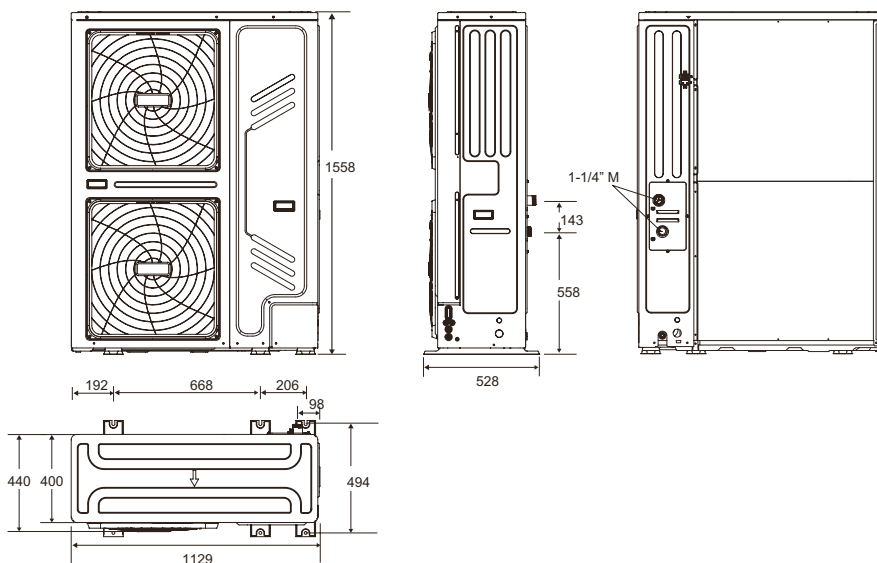

MODEL	22T	26T	30T
Packaging (W×H×D)	1220x1725x565		
Weight Net \ Gross	177 / 206		

Operating limits

COOLING MODE

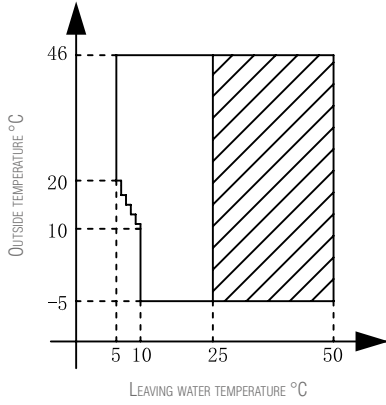

Water flow temperature drop or rise interval

HEATING MODE

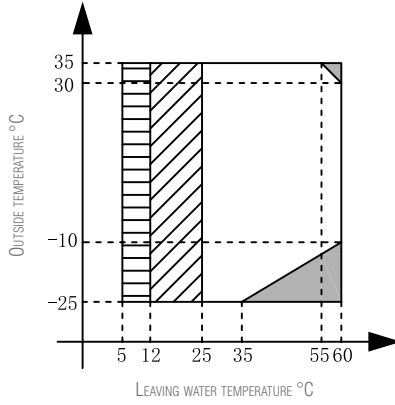

Water flow temperature drop or rise interval

No heat pump operation, IBH or AHS only

If IBH/AHS setting is valid, only IBH/AHS turns on. If IBH/AHS setting is invalid, only heat pump turns on

DHW MODE

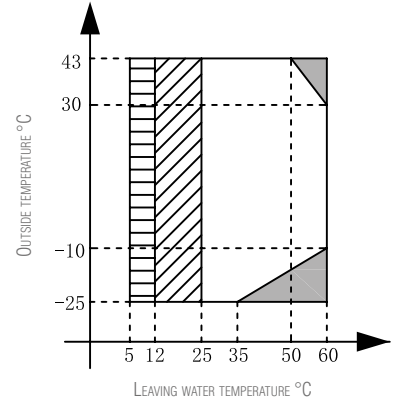

Water flow temperature drop or rise interval

No heat pump operation, IBH or AHS only

If IBH/AHS setting is valid, only IBH/AHS turns on. If IBH/AHS setting is invalid, only heat pump turns on

Minimun operating area

SINGLE UNIT INSTALLATION

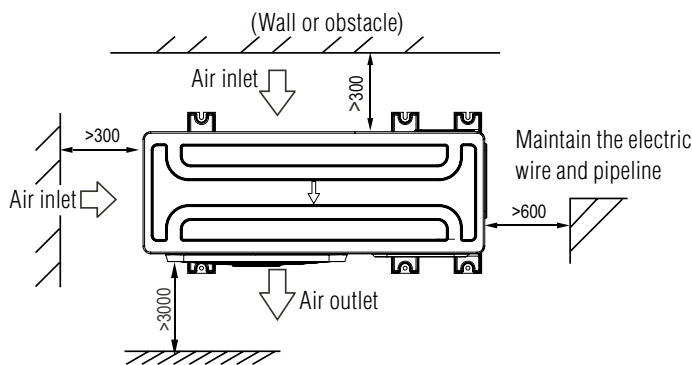

PARALLEL CONNECT THE TWO UNITS OR ABOVE

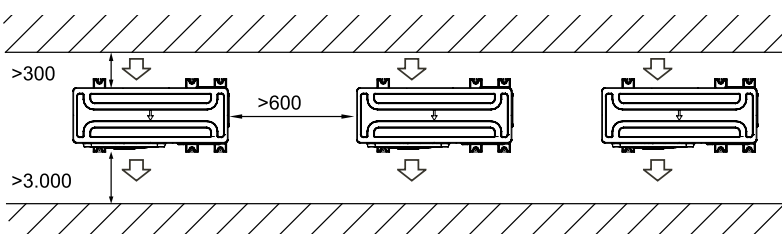

PARALLEL CONNECT THE FRONT WITH REAR SIDES

